

TECHNICAL BULLETIN

Prepared By:	Adrian Croft	Issue Date:	2 / 11 / 04
Reference:	WVC-BC004-R0	Pages:	7

Subject: **Desuperheaters**

INTRODUCTION

Desuperheaters are used to reduce the temperature of a vapour by the injection of a liquid cooling medium into the vapour stream. In the vast majority of applications, the vapour will be superheated steam that is being cooled by the injection of water. However, desuperheaters can also be used on other duties, including reducing natural gas temperatures in LNG plants, and Ethylene gas temperatures in process plants.

Desuperheaters can be supplied as stand alone items purely for temperature reduction, but they may also be supplied with a control valve to give a package that reduces both the vapour's pressure and temperature. Temperature reducing units are referred to as "Pipeline Desuperheaters", and pressure and temperature reducing units are referred to as "Combined Desuperheaters".

In order for the temperature to be reduced and controlled effectively, several conditions must be met. These include:

- Efficient atomisation of the cooling medium.
- A vapour velocity that promotes mixing.
- The correct cooling medium temperature.

This section defines how efficient desuperheating can be achieved, and sets

the recommended maximum and minimum limits for each of the parameters concerned.

Two types of desuperheater may be specified, fixed or variable area. The manual defines where each type should be applied and gives recommendations with respect to performance.

Refer to control valve selection for selection the reducing element of a combine unit.

Installation plays a very important part in successful desuperheating, and there are guidelines stated which show the recommended practices.

DESUPERHEATER TYPES

Fixed Area Designs

There are two types of fixed area design, the BV986 spraying, and the BV988 insertion probe type. Both designs require a separate control valve to regulate the flow of cooling medium that is being supplied to the vapour. Being fixed area, the pressure drop across the nozzle varies with flowrate, and as such their ability to atomise effectively over a range of conditions is restricted.

The BV986 uses plain drilled holes for the nozzles and is therefore the least effective atomiser. The BV988 uses profiled nozzles supplemented by swirl inserts,

Technical Bulletin Continuation Sheet

and is therefore more effective at atomising, especially at lower pressure drops. Table D.1. details the minimum pressure drops required to atomise the cooling medium, and flow turndowns that can be achieved with this design of unit. The maximum pressure drop across fixed area spray units is restricted to 50 bar, to avoid erosion.

Fig D.1 BV986 Mini Desuperheater

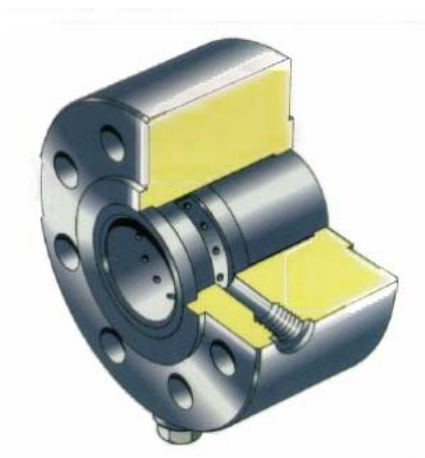

Whether to use the BV986 or BV988 will be determined by a combination of vapour pipe size and required flow coefficient. Both designs can be supplied as pipeline desuperheaters, or as part of a combined unit. When specifying combined units with weld end connections, it is preferable from a maintenance perspective to offer the BV988 type. Table D.2 provides selection guidelines.

Variable Area Design

The BV985 is the company's variable area design. It is a multi-nozzle type, and combines the functions of atomisation and cooling medium flow control. This is achieved by the linear movement of a plug

which gradually uncovers the nozzles as the movement increases.

Fig D.2 BV985 Variable Area Unit

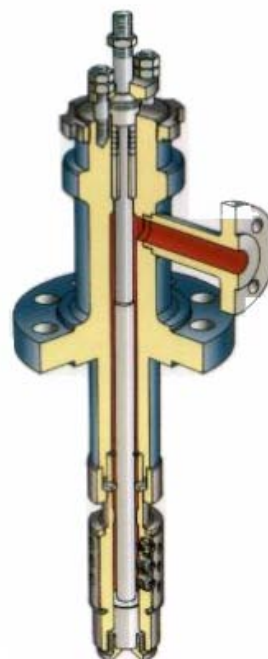

The design uses profiled spray nozzles supplemented by swirl inserts. Because a constant pressure drop is maintained at the spray insert irrespective of flowrate, the variable area design has a higher turndown capability than the fixed area design. Table D.1 details the standard turndown ratios. It should be noted that it is possible in some cases to improve on these by supplying characterised arrangements using several different nozzle sizes. Engineering should be consulted on an individual basis.

Where the pressure differential between the cooling medium and the vapour exceeds 60 bar, a two stage version is available that will extend the allowable

Technical Bulletin Continuation Sheet

pressure drop to 100 bar. Above 100 bar, a separate pressure reducing valve will have to be specified.

The variable area units are subject to arduous conditions, and their use as a shut off valve should be dissuaded where ever possible. While the design is capable of giving class V leakage in the manufactured condition, this degree of shut off would be unlikely to be maintained once the valve was in service.

Where a shut off function is required, it is better to specify a fixed area unit with a separate control valve where turndown requirements permit. If the variable area unit has to be selected, a motorised isolation valve should be recommended. This should be installed upstream of the desuperheater, and configured in the control system to close when the desuperheater is closed.

FACTORS AFFECTING EFFICIENT DESUPERHEATING

Cooling medium atomisation

The greatest influence on the size of the atomised cooling medium droplet is the pressure drop across the spray nozzle. As the pressure drop increases, the droplet size will reduce. A small droplet size is desirable, as it will evaporate more readily and give improved desuperheating efficiency. Figure D.3 gives details of the expected droplet size, considering pressure the drop criteria. The design of the nozzle will affect the size of the droplet to some extent, especially at lower pressure drops. Table D.1 details the minimum pressure drop that will achieve

effective atomisation for the various spray nozzle designs. The maximum pressure drop across the spray nozzle is restricted to 50 bar in order to avoid flow erosion.

Cooling Medium Temperature

Ideally, the temperature of the cooling medium should be as close as possible to saturation so that only latent heat is added, following injection, and the time to achieve complete evaporation is reduced. If possible, the temperature should not be less than 60°C.

Vapour Velocity

The velocity of the vapour is important, too high and the cooling medium will not have sufficient time to evaporate before reaching the sensing point. Too low and it will not generate sufficient turbulence to promote efficient mixing.

Ratio of Cooling Medium to Vapour

In order to achieve efficient desuperheating, the ratio of injected cooling medium to vapour should be limited. It should be noted that the use of baffles on combined units increases the allowable cooling medium ratios. This is because the extra turbulence they create helps to increase mixing efficiency.

Conditioned temperature

The closer the conditioned temperature is to saturation, the more difficult temperature control becomes. The minimum amount of superheat on the conditioned vapour temperature should be +5°C. As the required conditioned

Technical Bulletin Continuation Sheet

temperature approaches this value, positioning of the temperature measuring element becomes more critical, in order to prevent the sensor from becoming “wet” and giving erroneous readings.

Once again, these comments apply to process desuperheating applications where good temperature control is required. For turbine bypass applications desuperheating to the saturation point is permissible, and the distance to the temperature sensing point is not applicable, since cooling medium control is usually flow rather than temperature based.

Calculating Required Cooling Medium

The required cooling medium ratio is calculated by a simple heat balance formula:

Cooling medium ratio (R)

$$R = \frac{h_i - h_o}{h_o - h_w}$$

Where

h_i = Enthalpy of Vapour at inlet condition.

h_o = Enthalpy of Vapour at outlet condition.

h_w = Enthalpy of cooling medium.

The required cooling medium flowrate is then calculated as follows:

Vapour flowrate specified at the inlet condition

$$F_w = F_{vi} \times R$$

Where

F_w = Cooling medium flowrate

F_{vi} = Vapour flowrate

R = Cooling medium ratio

Vapour flowrate specified at the outlet condition

$$F_w = F_{vo} - \frac{F_{vo}}{(1 + R)}$$

Where

F_w = Cooling medium flowrate

F_{vo} = Vapour flowrate

R = Cooling medium ratio

For steam desuperheating applications, the enthalpy values can be taken directly from standard steam tables. For other types of desuperheaters, the enthalpy values can usually be obtained from reference books or the internet if they have not been provided the customer. Perrys Chemical Engineers Handbook is a useful source of information, as is the following website, www.questconsult.com

Thermal Liners

On certain applications, it is good practice to recommend the use of a thermal liner with variable area desuperheaters. The liner is used to protect the pressure containing wall of the pipe from thermal shock due to cooling medium impingement. Liners are normally designed to be fixed at the end prior to the desuperheater, and free, but guided at the other. This allows them some degree of freedom to expand.

The need for a liner will depend on several aspects of the application, these must be rated individually, and then added together to determine if a liner should be recommended. The aspects requiring consideration are outlined below.

Technical Bulletin Continuation Sheet

- *Cooling medium temperature* - the potential for thermal cracking increases as cooling medium temperature reduces.
- *Cooling medium atomisation* - the greater the droplet size, the greater the risk of impingement due to unabsorbed water. Droplet size is largely dependent on the pressure drop at the desuperheater nozzle, therefore the lower the pressure drop, the greater the risk.
- *Cooling medium flow ratio* - the higher the percentage cooling medium flow, the greater the risk of unabsorbed water impingement at the point of injection.
- *Vapour flow velocity* - At lower velocities mixing will not be efficient, and the potential for cooling medium impingement is increased.

In addition to providing protection for the pressure containing pipe, liners can be used to locally increase the steam velocity on applications where the velocity does not meet the recommended limit to achieve effective mixing.

INSTALLATION

Piping

Desuperheaters should be preferably installed in horizontal pipe runs. Where they are installed in a vertical pipe run, the spray direction must be vertically down. The length of straight pipe after the point of cooling medium injection should be as

long as possible, to avoid erosion of the first bend. Where these cannot be met, long radius type elbows should be used. The requirements for upstream straight piping are the same as for control valves.

Drainage

Horizontal pipe runs should have a fall of 20mm per metre to ensure effective drainage of unabsorbed cooling medium. A Trap should be positioned at the lowest point in the piping. The capacity of the trap should be at least 10% of the maximum rated cooling medium flow. Lagging the piping will promote efficient desuperheating.

Location of Temperature Sensor

The distance between the point of cooling medium injection and the temperature sensor will depend on the enthalpy change of the vapour, and the proximity of the conditioned temperature to the saturation point. It is not necessary to have a continuous length of straight pipe between the point of injection and the temperature sensor. However, the sensor should be located in a straight length of pipe, at least 2 metres away from a bend. The sensor should extend into the pipe by a 1/3 to 1/2 the diameter on pipe sizes up to 300mm, and by 1/4 to a 1/3 on pipe sizes above 300mm.

Cooling Medium Filtration

Because the flow passages in desuperheaters are often very small, it is important that the cooling medium is effectively filtered to 0.25mm to prevent blockage

Technical Bulletin Continuation Sheet

Table D.1 Minimum Pressure Drops Required for Atomising and Max Turndowns

Model No	Desuperheater Type	Cv	Min. Pressure drop (bar)	Maximum Turndown
BV986	Fixed Area	0.03 to 10.0	2	5:1
BV988	Fixed Area (Lechler)	0.033	0.5	10:1
		0.053		
		0.066		
		0.084		
		0.105		
		0.131		
		0.166		
		0.210		
		0.263		
		0.331		
		0.373		
		0.420		
		0.447		
		0.473		
		0.526		
0.657				
0.842				
1.052				
BV988	Fixed Area (Swirl)*	0.5	1.0	7:1
		0.9		
		1.5		
		2.7		
		4.7		
		8		
		10		
BV985	Variable Area (Swirl)	0.5	1.0	12:1
		0.9		18:1
		1.5		24:1
		2.7		30:1
		4.7		36:1
		8.0		40:1
		10.0		48:1

Technical Bulletin Continuation Sheet

Table D.1 Recommended Desuperheater Type Based on Vapour Pipe Size

Model No	Desuperheater Type	Pipe Size Range (mm)
BV 986	Fixed Area	25 – 200
BV 988	Fixed Area (Lechler)	25 – 200
BV 988	Fixed Area (Swirl)	150 – 900
BV 985	Variable Area (Swirl)	150 -900

Figure D.1 Maximum Droplet Size Based on Cv and Pressure Drop

